

1366041

- (21) Application No. 34238/72 (22) Filed 21 July 1972
- (44) Complete Specification published 11 Sept. 1974
- (51) International Classification A61L 9/02
- (52) Index at acceptance
A5G 13 5E
- (72) Inventor SAKUJIRO OKUI



(54) DEVICE FOR VOLATILIZING INSECTICIDES AND THE LIKE

(71) We, KODAMA BROTHERS CO. LTD., of No. 29 Shimotsu-cho, Yoro, Kaise-gun, Wakayama-ken, Japan, a Body Corporate organised and existing under the laws of Japan, do hereby declare the invention, for which we pray that a patent may be granted to us, and the method by which it is to be performed, to be particularly described in and by the following statement:—

5 The present invention relates to a device for vulcanizing insecticides or the like.

10 In order to exterminate mosquitoes, flies and other insects which are harmful or irritating to men and beasts, it is customary to vaporize an insecticidal compound, so as to subject these insects to the vapour. The vaporization may be achieved by heating the solid or liquid compound.

15 For this purpose, use is often made of a device which includes a heating coil of Nichrome (Registered Trade Mark) wire, a heating plate, to which the heat from the heating coil is conducted, and a paste of the insecticide or a fibrous tissue board impregnated with the insecticide mounted on the heating plate. When the device is operated, heat from the heating coil is conducted to the heating plate and there vaporizes the insecticidal compound.

20 However, this type of device has the defect that it cannot be used without a readily accessible source of electricity; accordingly, if the device is to be moved from one position to another, such a source must be provided at each of the positions in which the device may be used.

25 In order to eliminate this disadvantage of this conventional device, certain improvements have been proposed, in which the device uses dry cells as the source of electricity to heat the Nichrome wire. However, the electricity consumed by the Nichrome wire is so great that, if the wire is to supply heat continuously, it will consume the electricity accumulated in the dry cells very quickly. This, of course, has the result that the user must often change

the cells, thus adding to the expense of the device.

30 Moreover, this device has the additional disadvantage that, as long as electricity flows through the Nichrome wire, it will continue to supply heat wastefully, even after the insecticidal compound has completely vaporized. If, therefore, the user operates the device while in bed, he might fall asleep, forgetting to switch off the electricity: the heating plate is easily overheated and could give rise to burns or even to a fire, whilst the user is sleeping.

35 The present invention overcomes the disadvantages of such known types of device for volatilizing insecticides as described above by using a liquified gas as fuel, thereby taking advantage of the fact that the gas may be liquified to occupy a very small volume in a fuel storage tank but may subsequently expand to a very large volume when allowed to resume its gaseous state.

40 The invention provides a device for volatilizing insecticides or the like, comprising: a fuel storage tank having an inlet for the supply of a liquified gaseous fuel thereto and an outlet; a heat radiation system comprising a catalyst for the combustion of said fuel and a carrier for said catalyst; means for holding or maintaining a volatilizable insecticide or the like in proximity to the said radiation system in a position such that the vapours produced may disseminate into the atmosphere; a conduit for supplying said fuel from said tank to said heat radiation system; a valve for cutting off supply of fuel to said conduit; a heat-actuatable switch for closing said valve when said temperature of the device in the region of the switch exceeds a predetermined value; and an ignition system for igniting fuel supplied to the heat radiation system whereby the fuel burns in the presence of said catalyst to generate heat sufficient to vaporize the said insecticides or the like.

45 The device is preferably supplied with a cover for the said catalyst carrier to prevent

scattering and loss of the carrier for the catalyst. This carrier is preferably made up of fire-proof fibrous tissues, such as asbestos or glass wool. The ejected gaseous fuel is thus continuously oxidised in the presence of the catalyst to provide a smokeless and odourless heat source.

The fuel storage tank and/or the conduit connecting the tank to the heat radiation system preferably comprise a heat-insulating material, so that heat generated in the radiation system is not conducted back to the pipe and to the tank, which otherwise might be damaged by overheating. In practice, we prefer that the tank should be wholly or partially covered by the heat-insulating material and that at least the portion of the conduit between the valve and the tank should be made of such material.

The provision of the heat-actuable switch is a safety device which automatically will stop the supply of liquefied gas when the radiation system overheats, thus preventing the risk of burns or fires.

The invention is further illustrated with reference to the accompanying drawings, in which:

Figure 1 is a perspective view of a preferred embodiment of a device for volatilizing insecticides and the like, according to the present invention;

Figure 2 is a diagrammatic view, partly in section, of the device shown in Figure 1;

Figure 3 is a perspective view of a fibrous tissue board impregnated with the insecticidal compound and to be used in the device shown in Figure 1; and

Figure 4 is a diagrammatic view, partly in section, of a modified device volatilizing insecticides and the like, in accordance with the present invention.

Referring now particularly to Figures 1 and 2, the device A for volatilizing insecticides and the like comprises a housing 10 containing a fuel storage tank 11, fuel supply means shown generally at 20, a safety device shown generally at 30, an ignition system shown generally at 40 and a radiation system shown generally at 50. The housing 10 may be formed into any desired shape and is preferably made of a heat-insulating material.

The fuel storage tank 11 is made up of a metallic layer 12 and a heat-insulating coating 13 composed, for example, of a fluorocarbon resin or a silicone resin, so that, even if device A is overheated by the supply of too much liquefied gas due, perhaps, to an accident with the valve provided to regulate the supply of the gas, the heat is completely prevented from being conducted to the fuel storage tank 11.

Since fluorocarbon resins are generally proof against heat up to 350°C and silicone resins to about 1500°C, the heat-insulating coating 13 need not be used to cover the

whole of metallic layer 12 but need only be used to cover those portions thereof which abut directly upon housing 10 and which might therefore be excessively heated.

Tank 11 is further provided with an inlet 14 for the supply of the liquefied gaseous fuel and an outlet 15, to which a fuel supply conduit 21 is connected. Inlet 14 is exposed to the outside of the device and is of such a shape as to accept commercially available liquefied gas containers so that the user can easily fill the tank with a liquefied gas, such as butane, which is commercially sold for refilling cigarette lighters.

The fuel supply system 20 includes a pair of fuel supply conduits 21 and 22 and a valve 23 mounted between these conduits, so as to regulate the supply of the gaseous fuel. Conduit 21 is preferably composed of heat-insulating fluorocarbon or silicone resin, so as to prevent the heat of the device from being conducted to tank 11. On the other hand, conduit 22 is preferably made of metal, so that it may be firmly secured to the heat radiation system 15.

Regulating valve 23 may be of any type conventionally used to regulate the supply of liquefied gases: particularly suitable are those known for use in gas cigarette lighters.

The safety system 30 includes a bimetallic strip 31, which is so formed as to curve in one direction when it is heated to a certain temperature so that, if the radiation system 50 overheats due to the supply of too much liquefied gas and the temperature of device A in the region of the strip thus increases to a dangerous degree, the bimetallic strip 31 will bend to close valve 23, through actuating strip 24, thereby terminating the flow of liquefied gas 16 from tank 11 and automatically stopping any further heating of radiation system 50.

The safety system 30 is located in any suitable position within housing 10, provided that the bimetallic strip 31 should be in thermal communication with the heat radiation system.

The valve 23 is preferably such that, once closed by the bimetallic strip 31, it will remain closed until the user deliberately opens it. In place of the regulating valve 23, there may be used a thermostatic valve 23a (e.g. as shown in Figure 4), in which the valve 23 and the bimetallic actuator 31 are combined.

The ignition system 40 includes at least one dry cell 41, electrical contacts 42 and 43, electrical connections 44 and 45, a heating filament 46 and a switch 47. The electrical contacts 42 and 43 are made of a resilient metal and detachably hold the dry cell 41, in electrical contact with the positive and negative poles thereof, so that the dry cell, once used up, can easily be replaced.

Switch 47 is a normally open switch provided with a push button 47a, which, when pushed, permits electricity to flow through

electrical connections 44 and 45, thereby heating filament 46 to a red heat. Once the button is released, the flow of electricity ceases, and the filament 46 is no longer heated.

5 If desired, the ignition system 40 may be so mounted as to co-operate with safety system 30 and regulating valve 23, so that, if the device overheats, the bimetallic strip 31, will, as described above, close valve 23, thereby cutting off supply of the liquid gas, 10 but when the device has cooled, the valve 23 is automatically open to permit further supply of the liquid gaseous fuel to radiation system 50 and the ignition system 40 is automatically actuated to heat filament 46 to red heat, 15 thereby igniting gas 16.

Radiation system 50 includes a pinch of asbestos, glass wool or any other suitable carrier 51 which supports a catalyst, such as 20 platinum, palladium or a mixture thereof, to accelerate the combustion of the fuel. This carrier 51 is mounted adjacent the opening of conduit 22 and is protected by a suitable heat-proof mesh cover 52, which prevents 25 the scattering and loss of carrier 51. Over the outer surface of cover 52 is placed a metallic plate 53, on which may be mounted the insecticidal fibrous board 54 (Figure 3).

When the device A is used, the valve 23 is 30 opened to supply gas 16 to the radiation system 50 through metallic pipe 22 and the push button 47a of the normally open switch 47 is pushed to permit the passage of an electrical current through filament 46 until 35 it reaches red heat and ignites gas 16 in the radiation system 50.

For as long as valve 23 is open, the liquefied gaseous fuel will expand to a gas through 40 valve 23 and will be ejected through conduit 22 where it will be oxidised in the presence of the catalyst on carrier 51. If platinum is used as the catalyst, it will cause fiftysix times the amount of oxygen from the air to 45 be involved in the combustion of butane at a temperature of 400°C than would be used in the absence of the catalyst. This combustion generates 687 Kcal per gram molecule of butane, the combustion being represented by the chemical equation:

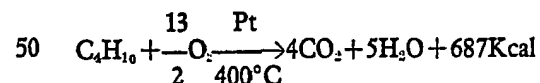

The heat thus produced is conducted directly to metallic plate 53, where it vaporizes the insecticidal compound impregnated in board 54.

55 Board 54 (Figure 3) is made of a suitable fibrous tissue impregnated with an insecticidal compound and is substantially the same shape as metallic plate 53, upon which it is placed when the device A is in use. The board 54 60 is preferably dyed with a dye which will fade as the insecticidal compound is vaporized,

so that the user can ascertain visually whether the board still contains an effective quantity of insecticidal compound.

Figure 4 of the accompanying drawings 65 shows a modified device A' for volatilizing insecticides and the like, in which those components which are essentially the same as the components of device A of Figures 1 and 2 70 are identified by the same reference numerals. In device A', the fibrous tissue board 54 is replaced by a roll of tape 63, the tape being made of a fibrous tissue impregnated with an insecticide and wound on a cylinder 62, so 75 that the tape can be fed over the heat radiation system 50 in the direction of arrow P. Cylinder 62 is rotatable about a shaft 61 held between two supports 60. The supports 60 are preferably made of a resilient material, 80 so that the shaft 61 can be easily detached therefrom and the cylinder 62 holding tape 63 can easily be replaced without using a screw driver or any other tool.

Tape 63 is guided over radiation system 50 by a pair of guide rolls 64 and 65 and is 85 driven by a drive system shown generally at 66. In order to minimize the cost of manufacture and maintenance, the drive system 66 is preferably a clockwork motor including 90 coil spring 68 having a key 67 whereby the coiled spring may be wound up and a pair of opposed rollers 69 and 70, which are driven by the coiled spring 68, roller 69 being driven in the clockwise direction shown by arrow 95 Q and roller 70 being driven in an anti-clockwise direction.

When device A' is to be used, spring 68 is wound up by turning key 67, and the spring thereupon drives rollers 69 and 70 100 through a gear mechanism (not shown). Simultaneously, the end of tape 63 is passed between rollers 69 and 70 over guide rolls 64 and 65. Rollers 69 and 70 then move clockwise and anti-clockwise to pull the tape 63 from cylinder 62 over radiation system 105 50. The speed at which tape 63 moves is dependent upon the rate at which the insecticide compound impregnated in the tape can be vaporized. The rotational speed of the rollers 69 and 70 is preferably adjusted to 110 the appropriate value by means of a suitable reduction mechanism.

The distance between the radiation system 50 and the portion of tape 63 passing directly 115 above it is preferably fixed so that the tape 63 is always heated to a temperature of about 60°C, at which temperature the vaporization may generally most effectively be accomplished. In addition, tape 63, like board 54 120 is preferably dyed with a dye which fades as the insecticidal compound vaporizes, so that the correct rotational speed of rollers 69 and 70 may easily be calculated.

In device A' shown in Figure 4, the housing 10 is provided with apertures 10a, through 125 which the fumes of the insecticidal compound

from tape 63 may be dissipated into the air.

The radiation system 50 is supported by stand 55.

5 In this embodiment, the valve 23 and bimetallic strip 31 of the embodiment shown in Figures 1 and 2 are replaced by a thermostatic valve 23a.

10 In place of filament 46 connected to dry cell 41 of both embodiments described above, a flint ignition system or a piezoelectric ignition system, such as are known for use in cigarette lighters, may be employed. It will be understood that the fuel may easily be ignited by means of a match if the dry cell is exhausted and no substitute dry cell is immediately available.

WHAT WE CLAIM IS:—

1. A device for volatilizing insecticides or the like, comprising: a fuel storage tank having an inlet for the supply of a liquefied gaseous fuel thereto and an outlet; a heat radiation system comprising a catalyst for the combustion of said fuel and a carrier for said catalyst; means for holding or maintaining a volatilizable insecticide or the like in proximity to the said radiation system in a position such that the vapours produced may disseminate into the atmosphere; a conduit for supplying said fuel from said tank to said heat radiation system; a valve for cutting off supply of fuel to said conduit; a heat-actuable switch for closing said valve when said temperature of the device in the region of the switch exceeds a predetermined value; and an ignition system for igniting fuel supplied to the heat radiation system whereby the fuel burns in the presence of said catalyst to generate heat sufficient to vaporize the said insecticides or the like.

40 2. A device as claimed in claim 1 further comprising a cover for the said catalyst carrier for preventing scattering and loss of said carrier.

45 3. A device as claimed in claim 1 or 2, wherein the ignition system comprises a dry

cell, a heating filament within said heat radiation system and electrical connections between said dry cell and said filament.

4. A device as claimed in any of claims 1 to 3, wherein said heat-actuable switch includes a bimetallic strip which bends to close said valve when the temperature of the device exceeds said predetermined value.

5. A device as claimed in any of claims 1 to 4, wherein said fuel storage tank comprises a metallic layer wholly or partially covered with a heat-insulating material.

6. A device as claimed in any of claims 1 to 5, wherein said catalyst is platinum.

7. A device as claimed in any of claims 1 to 5, wherein said catalyst is palladium.

8. A device as claimed in any of claims 1 to 7 wherein said support is a fire-proof fibrous material.

9. A device as claimed in claim 8 wherein said fibrous material is asbestos.

10. A device as claimed in claim 8 wherein said fibrous material is glass wool.

11. A device as claimed in any of claims 1 to 10 further comprising a metallic heating plate above said heat radiation system.

12. A device as claimed in any of claims 1 to 11 further comprising support means for a roll of tape impregnated with a volatilizable insecticide and the like; a pair of guide rolls to guide the tape over said heat radiation system, and a drive system for moving said tape.

13. A device as claimed in claim 12 wherein said drive system comprises a clock-work motor.

14. A device according to claim 1 substantially as herein described with reference to, and as shown in, Figures 1 and 2 of the accompanying drawings.

15. A device according to claim 1 substantially as herein described with reference to, and as shown in, Figure 4 of the accompanying drawings.

MARKS & CLERK.

FIG. 1

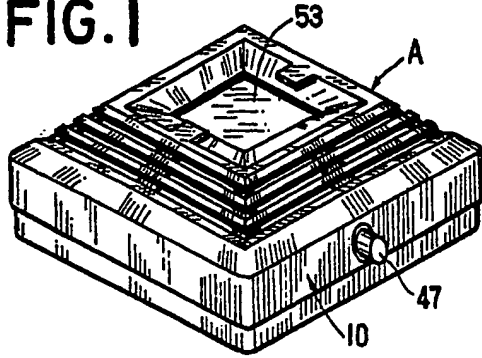

FIG. 3

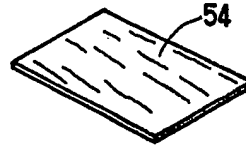

FIG. 2

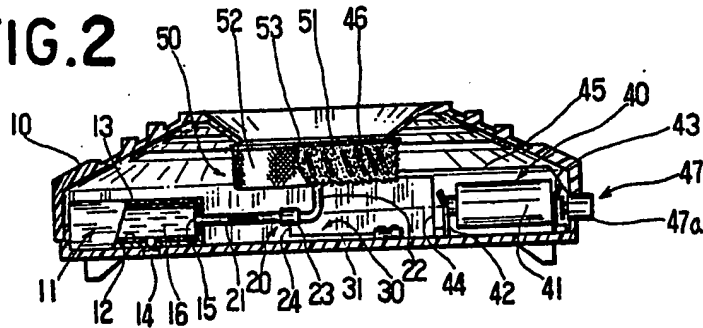

FIG. 4

